



Economical Electric School Bus (EESB)

Final Project Report – June 2, 2014

**Economical Electric School Bus EESB  
Final Report June 2<sup>nd</sup>, 2014**

Table of Contents

|  |    |
|--|----|
| Table of Figures .....   | 3  |
| 1.0 Executive Summary .....  | 4  |
| Project Highlights .....   | 5  |
| 2. Design Overview .....   | 5  |
| 2.1 Key Design Goals .....   | 5  |
| 2.2 Technologies and Methods Implemented .....                         | 6  |
| 2.3 Bus Vehicle Utilized .....   | 8  |
| 2.4 Component Selection .....  | 8  |
| 3. Vehicle Integration.....  | 10 |
| 3.1 Main Propulsion System .....                                       | 10 |
| 3.2 Inverter-Charger Subsystem .....                                   | 12 |
| 3.3 Energy Storage Subsystem .....                                     | 14 |
| 3.4 Electrically-Driven Accessory Subsystem.....                       | 16 |
| 3.5 Vehicle Control Subsystem.....                                     | 17 |
| 4. Bus Testing and Evaluation .....                                    | 18 |
| 4.1 CHP Approval Process .....   | 18 |
| 5.0 In-Service Demonstration .....                                     | 25 |
| 5.1 School System Integration .....                                    | 25 |
| 5.2 Charging Energy Efficiency and Cost .....                          | 27 |
| Chart showing kWh per mile in the first weeks of service at EUHSD..... | 28 |
| 5.3 Project Media Coverage.....  | 29 |
| 5.4 Project Lessons Learned .....                                      | 29 |
| 6.0 Conclusion .....   | 30 |

**Economical Electric School Bus EESB  
Final Report June 2<sup>nd</sup>, 2014**

**Table of Figures**

Figure 1: TransPower Electric School Bus showing battery compartments to Del Lago Academy of Applied Science ..... 4

Figure 2. Saf-T-Liner HDX chassis. .... 8

Figure 3: EESB Component Layout and Energy Flow ..... 9

Figure 4: EESB Motive Drive, 150 kW Motor connected to 7 Speed Eaton Transmission..... 9

Figure 5. Motor-transmission assembly used in EESB prototype. .... 11

Figure 6. View of main drive motor, transmission, and retarder from underside of bus..... 12

Figure 7. Drive components integrated into engine compartment; ICU is directly above drive motor, central control module is to the left, and electrically-driven braking and steering elements are to the right. .... 13

Figure 8. One of seven Mile-Max™ modules installed into EESB prototype. .... 14

Figure 9. Battery modules mounted in one side of EESB prototype luggage compartment. .... 15

Figure 10. Close-up view of electrically-driven accessory components. .... 16

Figure 11. Dashboard of EESB prototype. .... 17

Figure 12: Completed bus ..... 18

Figure 13: Battery compartment inspection..... 18

Figure 14. Battery compartment. .... 19

Figure 15. Powertrain..... 19

Figure 16. Professional Engineering Stamp regarding vehicle conversion manual ..... 25

Figure 17. EUHSD Route and Elevation Profile ..... 26

Figure 18. EESB Plugged In at CVUSD using same 208VAC panel as used for DPFs ..... 27

Figure 19. EUHSD kWh meter..... 27

Figure 20. EESB Daily Miles and kWh/mi AC in first weeks at EUHSD ..... 28

Figure 21. EESB Featured in San Diego Union Tribune..... 29

Figure 22. EESB at EUHSD Bus Yard..... 29

## 1.0 Executive Summary

The purpose of this document is to provide a final report on the *Economical Electric School Bus* (EESB) project. The EESB project was implemented by TransPower with funding from the California Air Resources Board under Grant Agreement No. G11-AQIP-03, which was administered by the San Diego Air Pollution Control District under Contract No. 541934. Under this project, a new 2008 Thomas Built HDX Transit Style School Bus was converted from conventional diesel power to plug-in battery-electric power.

The advanced battery-electric propulsion system developed for this bus was designed during the second half of 2012 and developed and installed into the bus during the first eight months of 2013. Drive testing of the prototype bus was initiated in late August 2013 and, under the auspices of the California Highway Patrol (CHP), a series of road tests and sequential safety improvements were made to the bus over the subsequent six months. On Feb 12, 2014, the vehicle received CHP approval and a CHP 292 certificate, allowing for transportation of students with the bus.

On March 17, 2014, the prototype bus initiated student service with Escondido Union High



Figure 1: TransPower Electric School Bus showing battery compartments to Del Lago Academy of Applied Science

School District, continuing to operate at this location for the planned period of one month. On April 28 the bus initiated student transportation services with the Cajon Valley Unified School District in El Cajon, CA. During these trials, the bus logged more than 1,600 miles during eight weeks of passenger service, regularly operating for 30-40 miles each day. The bus utilized approximately 60-80% of its rated battery capacity each day with an operating efficiency of about 2 kWh per mile, which equates to approximately 17 miles per gallon. The equivalent fuel cost for

**Economical Electric School Bus EESB  
Final Report June 2<sup>nd</sup>, 2014**

the prototype bus is estimated at \$0.22 per mile (based on \$0.11 per kWh), vs \$0.66 per mile for the comparable diesel bus (at \$4 / gallon diesel and 6 MPG).

## **Project Highlights**

- Logged over 2000 miles regularly driving 30-40 miles of daily service (62 miles max), consuming 60-80% of the battery rated capacity at an efficiency of about 2 kWh per mile or approximately 17 miles per gallon.
- Operated successful student service, with only 1 road call (loose transmission computer connector) and 2 unavailable starts (failed air compressor inverter, failed seatbelt) in 2 months at two districts
- The fuel cost is estimated at \$0.22 per mile (at \$0.11 per kWh), vs \$0.66 per mile for the comparable diesel bus (at \$4 / gallon diesel and 6 MPG)
- Bus recharged to full during the 4-6 hour mid-day break, even using the available 60 Amp outlets, which would relate to 80+ miles per day.
- Bus was featured in multiple local and national news articles and videos highlighting the benefits of the project, and the environmental stewardship of the project partners and operators.

## **2. Design Overview**

### **2.1 Key Design Goals**

The EESB project was conceived to achieve emissions reductions in California by producing the most affordable, practical, zero-emission school bus. Environmental stakeholders have dreamed of replacing conventional internal combustion engine (ICE)-driven school buses with buses using zero emission drive systems for years, but achievement of the goal of developing a practical zero emission school bus has proven to be very elusive. To date, only a handful of regularly-operating electric school buses have been built, and virtually none of these are of the larger vehicle models used to carry the majority of students. School districts remain reluctant to adopt zero emission buses because they have found them to be impractical for one or more of the following six reasons:

- Excessive capital cost
- Costly infrastructure requirements
- Complex operations
- Limited operating range
- Insufficient power
- Inadequate reliability

TransPower sought to address all of these issues by combining the latest battery-electric propulsion technologies with a variety of creative solutions to reducing system cost and the

**Economical Electric School Bus EESB  
Final Report June 2<sup>nd</sup>, 2014**

complexity of transit bus operations. Table 1 summarizes the design goals the EESB project pursued to address each of the six obstacles to zero emission bus adoption listed above.

*Table 1. Design goals for addressing barriers to zero emission school bus adoption.*

| <b>Barrier to Adoption</b>         | <b>Design Goals to Address Barrier</b>   |
|------------------------------------|--|
| Excessive capital cost             | Utilize low cost batteries and motors already manufactured in high volume, and combine the functions of the inverter and battery charger to reduce parts counts.   |
| Costly infrastructure requirements | Use advanced power electronics technologies to shrink the size of the battery charger, enabling it to be mounted on the bus. This eliminates the need for off-board charging infrastructure. Reliance on battery energy as opposed to hybrids (which still require fuel) eliminates the need for a refueling infrastructure. |
| Complex operations                 | Sufficient batteries are used to allow the bus to complete its duty cycle without “opportunity charging” in the middle of the route. Battery charging is required only at the completion of each duty cycle and is simplified by having the charger mounted on board the vehicle.  |
| Limited operating range            | High energy lithium-ion batteries are used to maximize operating range per weight of battery used, and large battery packs are employed to maximize the amount of stored energy on board the bus, increasing its range.  |
| Insufficient power                 | High-performance drive motors and a robust automated manual transmission are used in tandem to provide high torque and power, supplied in ample quantity by the large battery pack and high-power Inverter-Charger Unit (ICU).   |
| Inadequate reliability             | The battery-electric propulsion architecture is comparatively simple, with fewer moving parts than a conventional ICE or hybrid bus. This, along with high-quality component engineering and integration, will result in a bus with high reliability and low maintenance costs.  |

The EESB project was undertaken with the belief that if these design goals could be met, the project could have a transformative effect on the school bus market. Development of a practical zero-emission school bus has been a long-sought goal of the California Air Resources Board (ARB) and other regulatory agencies. It was believed that successful demonstration of the EESB buses in the San Diego County could lead to widespread adoption of such vehicles. The following subsections describe the engineering achievements of the EESB project in more detail.

## **2.2 Technologies and Methods Implemented**

The key enabling technologies for the EESB project, and the methods implemented, relate to the components of TransPower’s “ElecTrans™” electric drive system and how they are integrated into a robust vehicle architecture. ElecTrans™ is an adaptation of a proven battery-electric drive system, “ElecTruck™,” which uses a new high-power electric drive technology that was demonstrated concurrently with the EESB project in initial fleet of Class 8 electric drayage trucks and yard tractors. Therefore, the EESB engineering approach was to leverage and build logically



**Economical Electric School Bus EESB  
Final Report June 2<sup>nd</sup>, 2014**

on several related technology demonstrations. From a purely technical standpoint, the ElecTrans™ system to be installed into the EESB prototype was very similar to the drive systems installed into TransPower’s other vehicles, reducing project risks. Since all of TransPower’s targeted vehicle applications involve large vehicles that operate locally and perform lots of stop-and-go driving, school buses represent an attractive new adaptation of this zero-emission propulsion system. Table 2 lists the basic operating specifications established at the outset of the EESB project for the school bus variant of the ElecTrans™ system.

*Table 2. EESB bus operating specifications.*

| Operating Parameter     | Value  |
|-------------------------|--|
| Operating Range (miles) | 50-75  |
| Maximum Speed           | Up to 60 mph   |
| Gradability             | Sustained speed of 40 mph on a 2.5% grade and 10 mph on a 16% grade                |
| Acceleration            | Achieve 10 mph in 4 sec, 20 mph in 10 sec, 30 mph in 20 sec, and 40 mph in 35 sec. |
| Emissions               | None   |

Table 3 lists the principal design specifications established for the ElecTrans™ school bus drive system. The following subsections describe each of the major drive system components.

*Table 3. EESB design specifications.*

| Design Parameter  | Value                   |
|---|-------------------------|
| Number of drive motors  | 1                       |
| Drive motor size (mm)   | 810 x 221               |
| Drive motor weight (kg)   | 80                      |
| Drive motor power rating (kW)                                       | 100 continuous/150 peak |
| Maximum time at peak drive motor power (seconds)                    | 20                      |
| Inverter-charger weight (kg)  | 70                      |
| Number of inverter-charger units                                    | 1                       |
| Maximum inverter-charger power output (kW)                          | 150                     |
| Maximum inverter-charger power input for battery charging (kW each) | 70                      |
| Time to fully recharge batteries from 20% state-of-charge (minutes) | 90-120                  |
| Battery weight (kg per cell)  | 9.6                     |
| Battery capacity (ampere-hours, per cell)                           | 300                     |
| Battery cell chemistry  | Lithium iron phosphate  |

**Economical Electric School Bus EESB  
Final Report June 2<sup>nd</sup>, 2014**

|   |   |
|---|---|
| Number of battery cells per string                              | 112   |
| Number of battery strings                                       | 1 (additional strings can be added for increased operating range) |
| Total battery cell weight (kg)                                  | 1,120   |
| Nominal operating voltage (DC)                                  | 358.4   |
| Total battery energy storage capacity (kWh)                     | 108   |
| Total battery energy storage capacity, usable (kWh)             | 86  |
| Battery subsystem peak power rating (kW)                        | 302   |
| Battery thermal management type                                 | Forced air  |
| Battery lifetime (full discharge cycles to 20% state of charge) | 3,000   |

### 2.3 Bus Vehicle Utilized

For the EESB project, TransPower elected to install its new school bus drive system into a Thomas Built Saf-T-Liner HDX school bus. This is a large bus model with a seating capacity of 48 students with wheelchair lift (up to 84 in general configuration) and a gross vehicle weight rating of 36,200 lb. Operation of a transit bus of this size on battery power would be an unprecedented accomplishment.

Figure 1 shows the chassis of the Saf-T-Liner HDX. One of the noteworthy features of the chassis design is the large pass-through storage area, beneath the passenger compartment near the center of the chassis. This provided an ideal space for the lithium-ion batteries, approximately one ton of which would be needed for energy storage.



*Figure 2. Saf-T-Liner HDX chassis.*

### 2.4 Component Selection

TransPower's original intent for the EESB project was to use a drive system variant most similar to the drive system that TransPower had most recently installed into two Kalmar yard tractors, with slight modifications to accommodate the school bus application. Figure 3 illustrates the component layout and energy flow planned for the bus.



EESB Vehicle Component Layout

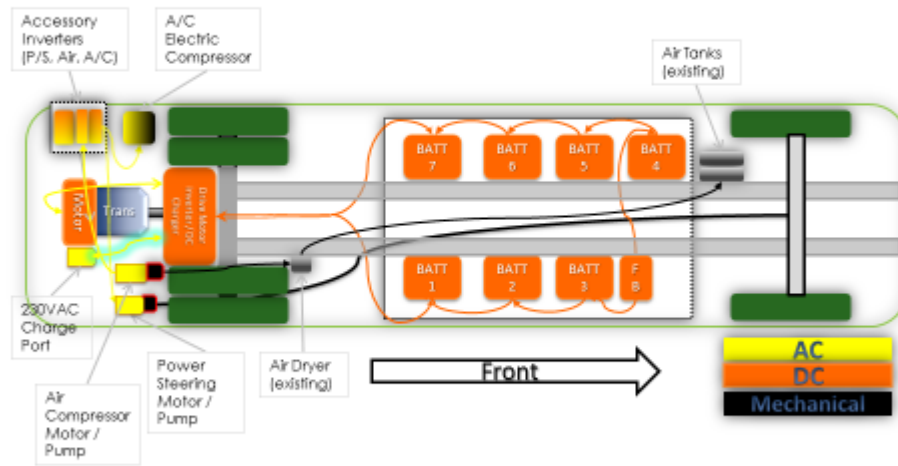



Figure 3. EESB Component Layout and Energy Flow 

TransPower initially validated its selected drive system architecture by using a powertrain simulator capable of calculating power, energy and braking requirements for a given route. TransPower collected GPS data from a representative school bus route which was then fed into the simulator. This allowed the engineering team to confirm that a single 150 kW motor would supply enough power, and that the next generation transmission planned by TransPower would have the appropriate gear ratios to balance the hill climbing and maximum speed requirements. This next generation transmission uses an Automated Manual Transmission that TransPower had demonstrated previously on two yard tractors, but that would be upgraded to use a new transmission manufactured by Eaton, which was expected to be more rugged than the transmissions installed into the earlier yard tractors. Figure 4 is an illustration of the main propulsion unit using the Fisker/JJE drive motor and Eaton transmission.

One important insight that was gained from this analysis was the need for additional braking assistance, especially for steep downhill segments. TransPower has thus specified an Electric Retarder, a component that is not needed for the Yard Truck application. The retarder has been installed into the EESB vehicle; once again, this is the very first TransPower vehicle to use this component.

The batteries and battery modules installed into the EESB vehicle were adapted from a Class 8 truck, in which these battery cells were cycled a few times to help validate the basic TransPower electric drive system control architecture. A fire suppression system – again the first to be installed into a

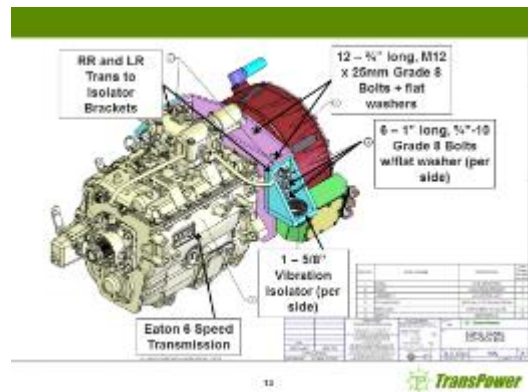

Figure 4. EESB Motive Drive, 150 kW Motor connected to 7 Speed Eaton Transmission.

TransPower vehicle – has been installed as part of the battery subsystem as an added safety feature. The electrically-driven accessories in the EESB, which provide power for power steering, braking, and heating and air conditioning, utilize the same components installed into other TransPower trucks and tractors over the past two years.

### **3. Vehicle Integration**

#### **3.1 Main Propulsion System**

The ElecTruck™/ElecTrans™ main propulsion subsystem (also referred to as “motive drive” subsystem) converts electrical power from the battery subsystem into mechanical power to drive the vehicle’s wheels. The primary component of this subsystem is the main drive motor. For our initial prototype vehicles, we evaluated numerous motor options and, after several months of analyses and discussions with motor manufacturers, made a novel choice in selecting a motor originally designed by JJE for a high-performance hybrid passenger car, the Fisker Karma. These motors each provide 150 kW of peak power, more than adequate to meet the most demanding truck and bus requirements (using two motors for larger vehicles). Adapting a motor designed for passenger cars has a potentially high payoff as these motors are more compact, lightweight, and economical than competing motors. They have also undergone extensive testing and certification to qualify them for automobile use, which adds to the degree of confidence in the reliability of the product.

The key challenge involved in adapting these motors for use in heavy-duty vehicles is generating sufficient torque for vehicles with higher weight ratings. In TransPower’s heaviest Class trucks, which have gross vehicle weight ratings of up to 80,000 lb., two JJE/Fisker motors are combined. In the EESB integration, we determined that a single motor was sufficient to meet the motive drive requirements for school buses weighing up to about 36,000 lb. One of the keys to obtaining adequate motor performance under all driving conditions is to mate the motor to a suitable transmission. To achieve this in the EESB application, as discussed previously, we mated the JJE/Fisker motor to a heavy-duty 6-speed Eaton manual transmission. Figure 4 is a photo of this propulsion unit prior to integration into the bus. A unique feature of this configuration is the use of the AMT technology that combines advanced Eaton and TransPower technologies. Visible near the top of Figure 5 is the Eaton shift mechanism used in the AMT, which employs servo motors that can mechanically shift the transmission’s gears in response to computer-generated commands. Also visible in the photo is the JJE/Fisker drive motor – the silver disk to the right – and the custom bell housing connecting the transmission to the motor.

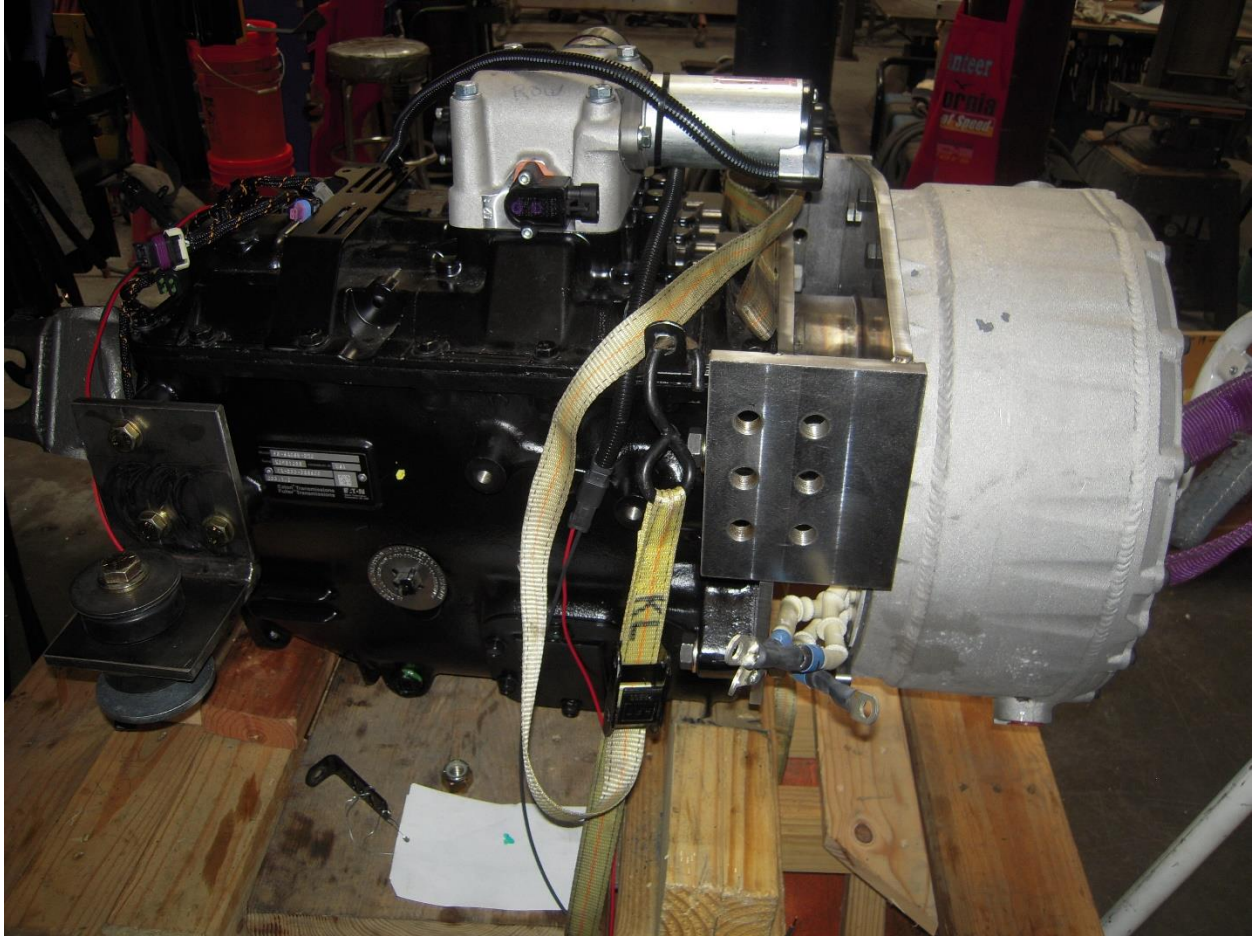

*Figure 5. Motor-transmission assembly used in EESB prototype.*

In all vehicles that used this Eaton transmission prior to TransPower's adaptation, Eaton software and controls were used to automatically shift the transmission. However, these vehicles all used conventional internal combustion engines. To make the Eaton transmission and shift mechanism work in TransPower's electric drive system, we had to develop our own software and controls. The scope of this task was significantly broader than anything that could have been accomplished on the EESB project alone, but fortunately TransPower initiated development of AMT technology on its previous electric yard tractor project, which provided an excellent head start for developing an AMT system compatible with the school bus application. In the yard tractor application, an early version of the AMT was developed using an older transmission and a shift mechanism built by a company called Mastershift for paddle shifters used on racing cars. While the first prototype tractors using this AMT configuration are operating satisfactorily, we believed that the Eaton transmission and shifter are more robust products that will offer a longer service life, with less maintenance. The prototype EESB bus thus became the first electric vehicle to use the new version of TransPower's AMT employing this more rugged Eaton hardware.

As compared with electric vehicles using direct drive motors, the AMT provides higher starting torque without compromising efficiency at higher operating speeds. As compared with electric vehicles using automatic transmissions, the AMT eliminates losses associated with torque converters. Maintaining high efficiency across the vehicle speed range and eliminating parasitic



losses such as those created by torque converters are important because these factors directly affect the operating range a vehicle can achieve on a single battery charge.

Figure 6 shows the motor-transmission assembly as integrated into the EESB vehicle. This photo was taken from underneath the bus, from the rear of the bus looking forward. As indicated, the JJE/Fisker motor is situated near the rear of the engine compartment, behind the transmission. Visible on the other side of the transmission is the Telma braking retarder we have incorporated into the design to provide additional braking authority. While the bus still has conventional service brakes and can use the JJE/Fisker motor for regenerative braking, the retarder provides an additional margin of safety, compensating for the loss of braking ability normally offered by the diesel engine in Thomas Built buses.

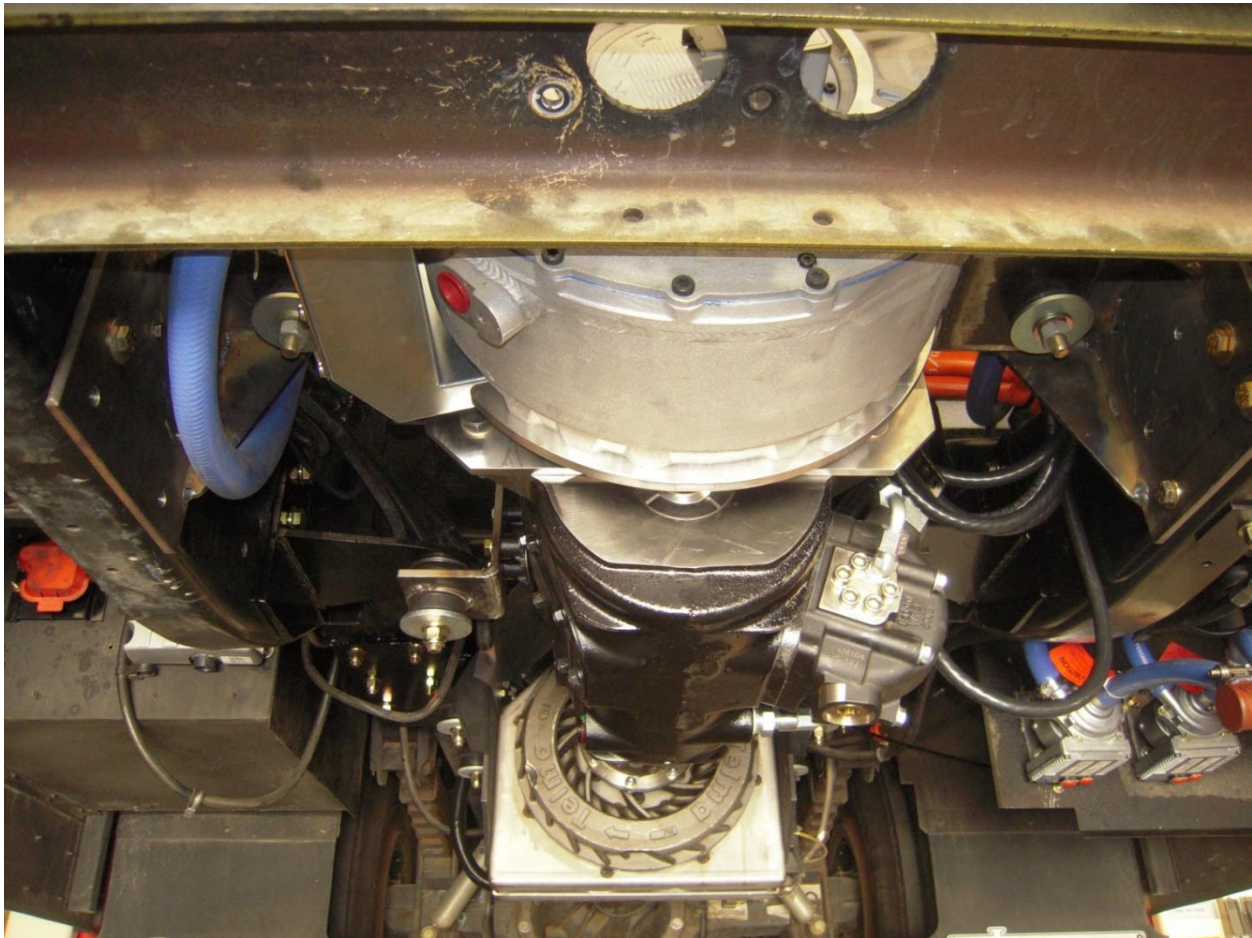

*Figure 6. View of main drive motor, transmission, and retarder from underside of bus.*

### 3.2 Inverter-Charger Subsystem

The inverter-charger subsystem (“ICS”) in the EESB application performs two vital functions: while the vehicle is moving, it converts DC power from the battery subsystem into AC power for the main drive motor, and while the vehicle is plugged in for recharging, it converts AC power from the grid into DC power to recharge the battery pack. The central component of the ICS is a

**Economical Electric School Bus EESB  
Final Report June 2<sup>nd</sup>, 2014**

new onboard Inverter-Charger Unit (ICU) TransPower developed for its initial prototype vehicles in partnership with EPC Power Corp, a startup company specializing in advanced power electronics. Figure 7 is a view of the EESB engine compartment showing the ICU, housed in a metallic enclosure, mounted directly above the drive motor. Toward the right end of the ICU is a cylindrical receptacle into which the charging plug is inserted to recharge the batteries.

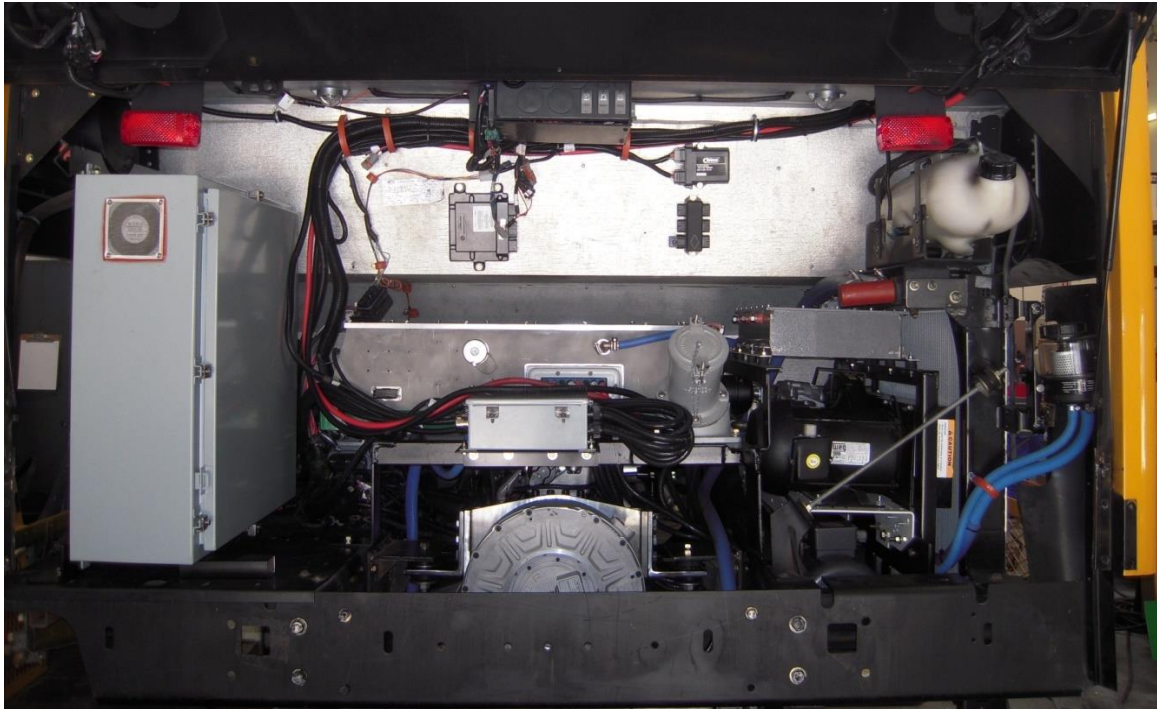

*Figure 7. Drive components integrated into engine compartment; ICU is directly above drive motor, central control module is to the left, and electrically-driven braking and steering elements are to the right.*

In early testing on TransPower’s first prototype on-road truck and our first two yard tractors, the ICU demonstrated the potential to revolutionize electric vehicle design by combining the functions of the inverter, which controls the drive motors, and the battery charger, which recharges the vehicle’s batteries on a “plug-in” basis. This innovation, which will reduce the overall cost of ownership of plug-in electric and hybrid vehicles, is made possible by several recent technical advances that have enabled TransPower and EPC to shrink the size of the magnetic materials required for high power, grid-compliant devices. These advances include new insulated gate bipolar transistors (IGBTs) that switch at higher frequencies than competing inverters, producing less electrical switching noise and reducing the materials required to filter this noise. Liquid-cooled heat sinks reduce the cost of cooling and improve reliability by eliminating fans, as well as contributing to the more compact, efficient ICU packaging. The ICU integrated into the EESB prototype can recharge the vehicle’s 100 kWh battery pack (see following section) at power levels of up to 70 kW, enabling the batteries to be fully charged within about one hour.

Also visible in Figure 7, to the far left of the engine compartment, is the central control module, which houses high-voltage distribution center, variable frequency drives that control the electrically-driven accessories, and various other electrical connections. Toward the lower right corner of the photo are various elements of the electrically-driven accessory subsystem, which



powers steering and braking without engine-driven power takeoff units. The integration of this subsystem is discussed in greater detail in Section 3.4.

### 3.3 Energy Storage Subsystem

The EESB energy storage subsystem (ESS) was designed to address the importance of battery performance by combining the best value lithium-ion batteries available anywhere in the world with a sophisticated battery management system (BMS) and a well-engineered integration concept. The intended result is an ESS with a lower cost of energy than competing systems, but that also offers high performance and long operating life – possibly as long as 10-15 years depending on how the batteries are utilized. The large format lithium iron phosphate (LiFePO<sub>4</sub>) cells we have selected for our ESS have shown favorable performance characteristics in various lab tests we have performed and in our first prototype vehicles, including high energy density and voltage and temperature stability. We also identified additional suppliers of such cells which enabled us to command more attractive prices and to obtain cells of different sizes that could be customized for a broad range of applications.

The EESB drive system takes advantage of an improved battery packaging concept we developed in late 2012 following several months of testing of batteries on our first prototype Class 8 truck. The improved design is based on a new “Mile-Max™” module, which has become our standard ESS building block. For the EESB application, each module contains 16 LiFePO<sub>4</sub> cells, each rated at 260 Ah, and stores about 13.3 kWh of energy. Seven of these modules were installed on our first prototype on-road truck in the summer of 2012, which was used as a “rolling test bed” to validate the proof of concept of the basic drive system architecture used in all our vehicle drive systems. As these batteries were cycled only a few times during the testing of this test bed truck in late 2012 and early 2013, they remain in nearly new condition and have been utilized in the EESB prototype. This saved not only the cost of purchasing new cells, but also saved the cost and risk of buying and integrating a new battery management system (BMS) and of installing the cells and BMS into seven Mile-Max™ modules. Figure 7 is a photo of one such module with its protective cover removed. The 16 green cells, 8 on each side, are barely visible beneath the black plastic cover plate to which the BMS sensors and cables are mounted. Each module weighs approximately 400 lb.

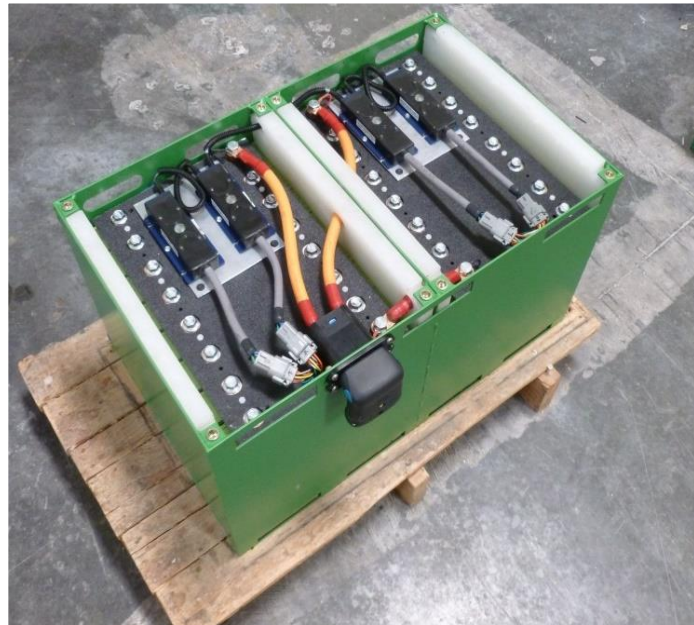

Figure 8. One of seven Mile-Max™ modules

For the EESB prototype, there was ample space in the luggage compartment beneath the floor of the passenger compartment for stowage of all seven battery modules. Our original concept was



**Economical Electric School Bus EESB  
Final Report June 2<sup>nd</sup>, 2014**

to install some of the modules within a channel that runs down the center of the luggage compartment, from the front toward the back of the compartment, and some of the modules in a new support structure under the floor, directly in front of the luggage compartment. This would have preserved most of the space normally available for luggage, or would have permitted installation of additional batteries in the unused luggage compartment space. However, it was subsequently determined that it would be more difficult to electrically connect modules inside and outside the luggage compartment, and that modules mounted under the bus and in the center luggage compartment channel would be difficult to access in the event they need to be serviced. For these reasons, we revised our design to simply install all seven modules in the outer sections of the luggage compartment, three on one side of the central channel and four on the other side. This limits luggage space but makes the modules much easier to access and service, which we felt was a far more important consideration for a prototype vehicle. The seven modules house a total of 112 cells, providing a total of 93 kilowatt-hours (kWh) of energy storage. This was later proven to be insufficient to achieve the initial design goal of providing 50-75 miles of driving range, based on maintenance of a minimum battery state of charge of at least 20%, but adequate for 40 miles of operating range fully loaded and 60-65 miles unloaded. It is anticipated that this will be adequate for most school transportation applications, since buses with longer routes can easily recharge the batteries between running their morning and afternoon routes.

Figure 9 shows the three battery modules installed on the side of the luggage compartment opposite the driver's side of the bus. Visible directly above the modules are fire retardant bottles which are part of the automatic fire suppression system we installed. While it is considered very unlikely that any kind of combustion will ever occur in this compartment, the fire suppression system provides an added margin of safety.



*Figure 9. Battery modules mounted in one side of EESB prototype luggage compartment.*

It should be noted that the luggage compartment floor of the Thomas Built bus is not designed to carry heavy loads and is not supporting the weight of the battery modules on its own. The weight of the battery modules is being primarily supported by heavy duty steel brackets bolted to the main frame rails. For future, production versions of the EESB, the luggage compartment can be structurally modified to provide greater floor support for batteries, as well as to make it easier

to stow batteries near the center of the compartment, increasing space available for luggage or additional batteries.

### 3.4 Electrically-Driven Accessory Subsystem

The EESB electrically-driven accessory subsystem (EDAS) was designed a new means of powering vehicle accessories such as power steering, braking, and heating, ventilation, and air conditioning. In conventional vehicles, these functions utilize engine-driven power takeoff units, but in TransPower electric vehicles, the engines are removed. Our EDAS assembly uses a rugged air compressor and hydraulic pump to make the bus accessories fully electric, allowing them to function without an engine or alternator. TransPower also supplies electrically-driven accessories to provide power for lighting, heating, air conditioning, and any other electrical loads. TransPower's accessories are activated only when required, which makes them significantly more energy-efficient than accessories that are run all the time. Figure 9 is a close-up view of the main EDAS components, installed to the right of the engine compartment (looking toward the front of the bus). To the far right of the photo is the radiator. The black cylinder to the left of the radiator near the top of the photo is the hydraulic pump and motor assembly used for the power steering system. The device installed directly below the hydraulic pump and motor is the motor and air compressor assembly used to charge the air system for the vehicle's brakes.

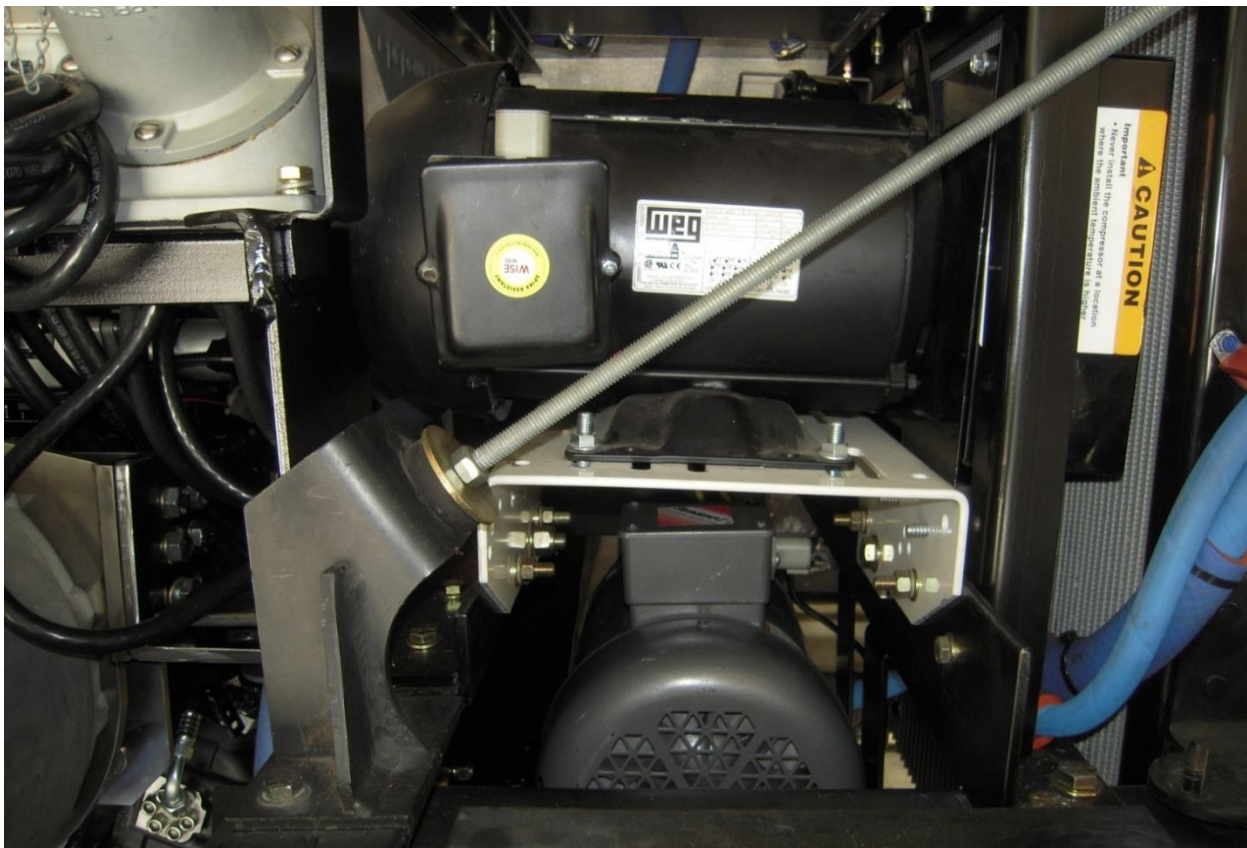

Figure 10. Close-up view of electrically-driven accessory components.

The motors for the accessories are controlled by variable frequency drives (VFDs) housed in the central control module, which isn't visible in Figure 9 but was shown in Figure 6. Our first two electric yard tractors exhibited intermittent VFD faults when initially operated at high power

levels. This problem was quickly traced to an incompatibility issue between the VFDs and the soft starter circuits that were initially employed in our EDAS design. We subsequently eliminated soft starters from our EDAS, employing a series of contactors instead and an additional VFD so we can separate continuously-running accessories such as power steering from ones that are activated intermittently such as charging the air system to maintain adequate pneumatic pressure for braking. These improvements have all been incorporated into the design and integration of the EESB accessory subsystem.

### 3.5 Vehicle Control Subsystem

The EESB vehicle control subsystem (VCS) controls all vehicle functions and makes the difference between battery-electric propulsion and conventional propulsion via internal combustion engines virtually transparent to the bus operator. All vehicle components are fully integrated into the vehicle's usual system of controls and displays, allowing drivers to easily monitor such parameters as vehicle speed and battery state of charge using dashboard displays similar to those to which they are accustomed. The VCS combines a network control architecture, control software, and power conversion modules into an integrated subsystem that links all drive system components and enables them to communicate with vehicle controls and displays. The VCS uses a Controller Area Network (CAN)-based architecture that offers unparalleled flexibility. Inexpensive, standardized microprocessors are used to interface each drive system component with the control network, similar to how PCs and peripherals can be linked in an office IT network using Ethernet connections.

In testing on our first prototype electric truck and tractors, the VCS has worked well, providing smooth vehicle control and facilitating the acquisition of data for diagnostic and other purposes. The EESB takes advantage of a redesigned central control module interior which makes the wiring cleaner and easier to service. The EESB prototype also employs improved shielding of cables which is expected to reduce noise issues that caused CAN communications difficulties during early in-service use of our electric yard tractors.

Figure 11 is a photo of the main dashboard of the EESB prototype, showing that the basic configuration of the dashboard is largely unaltered. Wiring diagrams and other information obtained from Thomas Built has enabled us to fully integrate our VCS with the bus's existing system of controls and displays, so drivers will be able to view vehicle speed and other simple parameters as they would in conventional school buses. One difference is our addition of a lever to enable the driver to activate the electric braking retarder, visible in the lower left corner of the photo. Directly above the lever is an indicator gauge that we installed to alert the driver when the retarder is engaged.



Figure 11. Dashboard of EESB prototype.



## Economical Electric School Bus EESB Final Report June 2<sup>nd</sup>, 2014

Figure 12 is a photo of the completed prototype school bus showing the batteries installed in the luggage compartment and a few of the components installed into the engine compartment,

### 4. Bus Testing and Evaluation

The prototype EESB vehicle turned out to be more electrically complex than expected, resulting in a relatively lengthy drive system validation process. The wheels of the bus were spun for the first time in early August 2013 and on August 21, 2013, the bus

was taken for its maiden test run. Following an initial series of test drives, we replaced both the main battery pack and the DC-to-DC converter. Drive testing resumed on September 3 after these items were replaced. Testing was then continued throughout an extensive commissioning and California Highway Patrol (CHP) approval process that was originally scheduled to conclude by November 20, 2013, but that wasn't completed until February 2014.

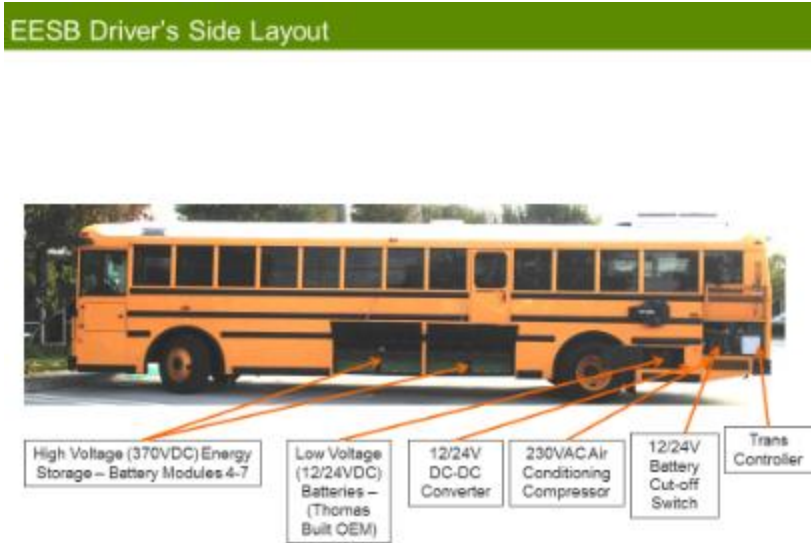

Figure 12: Completed bus.



### 4.1 CHP Approval Process

A team meeting was held on September 12<sup>th</sup>, 2013 comprising of representatives from TransPower, The San Diego County Air Pollution Control District (SDAPCD), the California Air Resources Board (ARB), the California Highway Patrol (CHP) and some of the San Diego County School Districts. The vehicle was available for static view using the vehicle lifts, and then taken out for a short demo drive. Jeff Picardi (CHP Motor Carrier Specialist III), Leonard Hazelwood (CHP Motor Carrier Specialist II) and two other CHP officers were present to help review the project.



Figure 13: Battery compartment inspection.

The CHP officers noted the following recommendations for items they suggested TransPower address prior to formal 292 inspections:

- Add a rear drive shaft protection strap
- Add additional “caging” or crash protection to the high voltage module mounting structure

**Economical Electric School Bus EESB  
Final Report June 2<sup>nd</sup>, 2014**

As a result, TransPower added the second drive shaft strap, and additional steel channel “crash bar” to the battery pack module’s mounting structure:



*Figure 14. Battery compartment.*

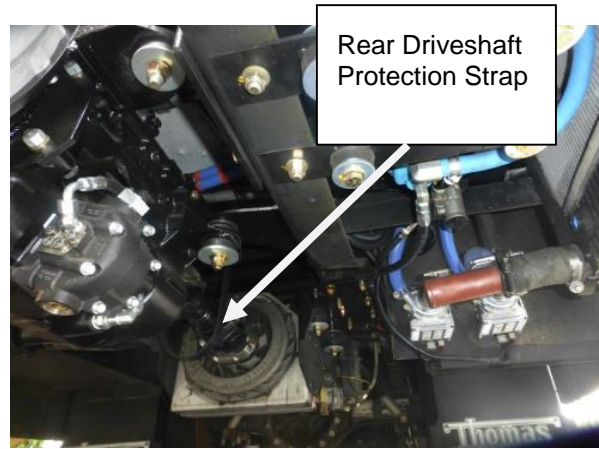

*Figure 15. Powertrain.*



On October 10<sup>th</sup>, 2013 Leonard Hazelwood and Leonel Ramirez, CHP Motor Carrier Specialist I, visited TransPower to perform the vehicle inspection using form CHP 294 – School Bus Initial Inspection. Joshua Goldman, TransPower VP of Business Development, and EESB Project Manager and others from the TransPower team were present to accompany the inspectors for the entire inspection. Upon arrival, Mr. Goldman provided Mr. Ramirez and Mr. Hazelwood with a tour of TransPower’s manufacturing, testing and engineering facility, including a detailed review with Dr. Paul Scott, one of TransPower’s senior scientists, and manager of battery testing and safety. At each stage of the tour Mr. Goldman reviewed TransPower prototyping and sub-system testing protocols and processes used to ensure safety of the EESB. Below is a photo of TransPower’s battery test lab, which contains state of the art equipment for battery safety testing, including an AV900 battery tester (far left in the photo) that has been used extensively to test the safety of the batteries used in TransPower vehicles.

Then the formal CHP294 inspection began with the bus up on vehicle lifts to ensure a complete interior and exterior inspection could be performed. Being the Initial School Bus Inspection and TransPower’s first CHP vehicle inspection, extra time and care was taken to inspect the entire vehicle, with additional TransPower staff included to ensure maximum value from the process.

The left column of Table 4 lists each of the deficiencies noted by the CHP inspectors during the October 10 visit. The middle column of Table 1 identifies the corrective action taken in response to each deficiency. The right column displays a photo of corrective action if applicable. As indicated in Table 1, most of these corrective actions were completed within one month and confirmed during a follow-up CHP inspection at TransPower’s facility on November 12, and of the four corrective actions not completed and confirmed at the November 12 inspection, three were completed on November 20. The final remaining corrective action – licensing of the bus – was completed after CHP approval by Escondido Union School District, the first fleet operator to demonstrate the bus in actual service.

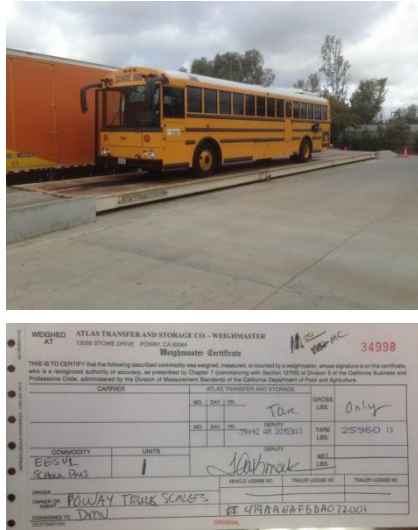

**Economical Electric School Bus EESB  
Final Report June 2<sup>nd</sup>, 2014**

*Table 4. Deficiencies noted during October 10 inspection, and corrective actions taken.*



| <b>Deficiency Noted on October 10<sup>th</sup>, 2013</b>   | <b>Corrective Action Taken</b>   | <b>Photo of Resolution</b>   |
|--|--|--|
| <p>Unladen weight is unofficial, carrier to obtain certified weight slip and display as require by 13 CCR 1272</p> | <p>Weight Slip Obtained, New Manufacturer Label Created and displayed 11/20/2013</p>   |    |
| <p>Speedometer Replaced as part of Re-Power. Carrier to provide FMVSS 101 plans for replacement</p>                | <p>FMVSS 101 speedometer plans presented along with MFG signed statement of speedometer accuracy and vehicle vs. EV drive miles 11/12/2013</p> |  |





**Economical Electric School Bus EESB  
Final Report June 2<sup>nd</sup>, 2014**

| <b>Deficiency Noted on<br/>October 10<sup>th</sup>, 2013</b> | <b>Corrective Action Taken</b>                                      | <b>Photo of Resolution</b>   |
|--|---|--|
| Vehicle Does not have effective defrosting device            | Defroster repaired<br>11/11/2013                                    |    |
| No current Annual Certification of fire extinguisher(s)      | Fire extinguishers serviced<br>10/15/2013                           |   |
| No CA number, carrier Name, or bus number displayed          | CA# and operator label created and adhered to vehicle<br>11/11/2013 |  |

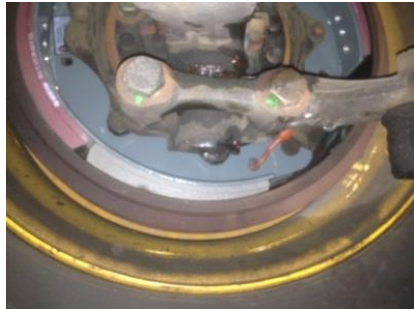
Economical Electric School Bus EESB  
Final Report June 2<sup>nd</sup>, 2014

| Deficiency Noted on October 10 <sup>th</sup> , 2013              | Corrective Action Taken                              | Photo of Resolution  |
|--|--|--|
| Axle 2 Electrical Line grommet displaced                         | Axle 2 electric line grommet replaced<br>10/10/2013  |    |
| Exhaust hole in bumper must be filled, could be used as foothold | Bumper exhaust hole filled<br>10/10/2013             |   |
| Axle 1 right side oil soaked brake linings                       | Front-right side brake linings replaced<br>11/8/2013 |  |

**Economical Electric School Bus EESB  
Final Report June 2<sup>nd</sup>, 2014**

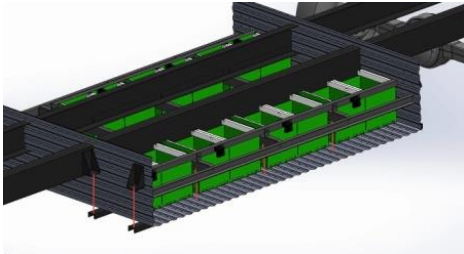
| <b>Deficiency Noted on October 10<sup>th</sup>, 2013</b>  | <b>Corrective Action Taken</b>   | <b>Photo of Resolution</b>   |
|---|--|--|
| Wheelchair loading device does not have padding   | Wheelchair padding replaced<br>11/20/2013  |    |
| Right side axle 1 tie rod end appears worn  | Front tie rod bushing greased<br>11/11/2013, Replaced<br>3/25/2014   |  |
| Noticeable Sag (or bow) at the floor for the under-body storage compartment where the batteries are stowed. | Frame Rail Mounted Structure was implemented to increase strength of baggage bay. Noticeable sag is part of structure's being under tension. Tie rods adjusted to ensure underbody C-Channel trued straight.<br>10/18/2013 |  |

**Economical Electric School Bus EESB  
Final Report June 2<sup>nd</sup>, 2014**

| Deficiency Noted on October 10 <sup>th</sup> , 2013  | Corrective Action Taken  | Photo of Resolution  |
|--|--|--|
|  |  |  |
| <p>Vehicle is not currently registered in California. Displaying MFG license plate which is not valid for transportation of school pupils.</p> | <p>Bus to be licensed by each fleet operator to be operating bus for planned demonstration</p> |  |

On November 21<sup>st</sup>, Mr. Goldman from TransPower, Earl Landberg and John Kato from the Air Resources Board met with Cullen Sisskind from the California Highway Patrol. The result of the meeting was the engagement of a direct relationship between TransPower and CHP, and specific direction on the documentation and certification CHP required for approval.

On November 28<sup>th</sup>, TransPower received an example document from CHP of a CNG tank replacement guide, which was used as a model for the creation of the TransPower Economical Electric School Bus (EESB) Installation Guide (EESB-INST-20140113 Rev A). This document was sent to CHP in final draft form late December, where CHP instructed TransPower that the “independent engineering review” required by CA Title 13 must be mechanical in nature. TransPower then continued with the Electrical Professional Engineering review, and was fortunate to engage early January with Poway Engineering Corporation, who performed the structural review.

**Economical Electric School Bus EESB  
Final Report June 2<sup>nd</sup>, 2014**

Economical Electric School Bus (EESB)  
Installation Guide

EESB-INST-2040113 Rev A

**Professional Engineer Statement of Compliance**

I, Michael W. Devine, CA Licensed Structural Engineer #4011, CA Licensed Civil Engineer #45633, hereby certify that this installation manual conforms to a sound mechanical and structural conversion of a TransPower electric drive system into a conventional Thomas HDX bus.

X

Michael W. Devine - Poway Engineering Corp  
RCE 45633, RSE 4011



*Figure 16. Professional Engineering Stamp regarding vehicle conversion manual*

The complete document with this new PE Stamp, as shown in Figure 16, was delivered to Cullen Sisskind at CHP and after one final layout and visual update, was deemed compliant with Title 13.

## **5.0 In-Service Demonstration**

### **5.1 School System Integration**

A 6- month leasing agreement between TransPower and Escondido Union High School District (EUHSD) was enacted putting EUHSD as the lead school district for the field demonstration phase of the project. During February to early March 2014 operators were trained, routes selected, and charging infrastructure installed at EUHSD. After 4 weeks of testing in Escondido, CA and a brief inspection of the system at TransPower over the spring break holiday, the vehicle was transferred to Cajon Valley Unified School District. Then after another 2 weeks of CHP re-certification, 45-day inspection, operator training, route selection and infrastructure installation, the EESB was able to begin its 4+ week carrying students at EUHSD throughout El Cajon, CA and surrounding communities. As of the time of this report, the EESB is continuing its pupil service for the remainder of the EUHSD school year. Further research and showcasing of the bus will happen in the summer of 2014. The bus will then go back to demonstration service in the fall of 2014 with additional San Diego County school districts.

The EESB has completed 2 solid months of demonstration service with two San Diego County school districts: Escondido Union High School District and Cajon Valley Unified School District. Given the prototype state of the vehicle, these field trials have been a glowing success.

The EESB was generally operated for 30-42 miles each morning, plus additional miles for testing and/or further demonstration. The routes chosen were fairly demanding routes and an

**Economical Electric School Bus EESB  
Final Report June 2<sup>nd</sup>, 2014**

excellent test profile for the bus. Each day it travelled on 45-55 mph surface streets, on a 65 mph highway, up substantial 8%+ grades, and through low speed stop and go urban centers. Figure 17 shows the route layout on a satellite topographical map with elevation profile



*Figure 17. EUHSD Route and Elevation Profile*

Only a handful of days of missed service occurred. Ironically, there was longer downtime (3 days) for a mass produced seatbelt, than due to the advanced battery electric drive system components (1 day each). Table 5 below describes the issues, length of downtime, root cause, immediate resolution, and improvements intended for next generation systems.

*Table 5: issues reported and the resolution:*

| <b>Issue</b>                              | <b>Downtime</b> | <b>Cause</b>   | <b>Resolution</b>                           | <b>Next Generation</b>   |
|---|-----------------|--|---|--|
| Faulty Transmission controller connection | 1 day           | Prototype terminal connection                                | Repaired Connection                         | Production system eliminate of transmission controller and connection                  |
| Inverter                                  | 1 day           | Undersized Inverter ran too hot in heat during week of fires | Replaced Failed 2.2 kW Inverter 3.7 kW unit | Incorporated Production water cooled, dual 30 kW, Automotive grade, accessory inverter |
| Failed Driver's Seatbelt                  | 3 days          | Belt rubbed, twisted and would not retract                   | Replaced with Factory Part                  | OEM to resolve   |



## 5.2 Charging Energy Efficiency and Cost

The EESB has an industry first 70 kW bi-directional on-board fast charging unit which can recharge the bus in as little as 90 minutes, and provide almost 100 kWh's back to the grid via its Vehicle to Grid (V2G) capabilities. Such a 208 VAC, 200 Amp, 3-phase charger connection can cost a few thousand dollars to install, though it can generate over \$100k in V2G revenue. As a compromise for these month long demonstrations at each district, a few hundred dollar, 60 Amp, 5 hour charge port was installed. Of note, at CVUSD the same panel used for their electronically regenerated Diesel Particulate Filters, was easily adapted to charge the electric bus.



Figure 18. EESB Plugged In at CVUSD using same 208VAC panel as used for DPFs

As an added bonus to the project, EUHSD took the extra expense and install an off-board kWh meter specific to the bus' charge port allowing for better AC energy and costing calculations. Generally the bus would consume about 1.9 to 2.1 kWh of battery energy per mile, which related to about 2.2 to 2.5 kWh/mile AC. These charge events would take 4-5 hours to replenish the routes consumed energy, then the system would go into trickle charge in order to the batteries balanced. Future battery pack designs will do constant balancing while in route, eliminating the extra few kWh's consumed during the demonstration for overnight balancing.

In future projects, where a bus of this type will spend years of service, the larger 200Amp outlet makes economic sense to install. This will also allow for recurring use of the bus throughout the day allowing for 80+ miles of daily service, and meeting the needs of much of the routes in urban and suburban pupil transportation.



Figure 19. EUHSD kWh meter

**Economical Electric School Bus EESB  
Final Report June 2<sup>nd</sup>, 2014**

The cost of charging the 80 kWh's at EUHSD was estimated at about \$8 (\$.11 per kWh). Because the vehicle would finish charging well before other high demand loads on site such as air conditioning, demand charges were not a significant factor in the charging costs. This cost relates to about **\$0.22 per mile** (at \$0.11 per kWh), vs **\$0.66 per mile** for the comparable diesel bus (at \$4 / gallon diesel and 6 MPG). At 12k miles per year this could relate **\$6k per year** in fuel cost savings.

Below is a chart highlighting the daily 40+ miles of operation at Escondido Union High School District and the Kilowatt-Hours per mile (kWh/mile) as calculated from the AC meter. Also of note, is the operator was able to become accustomed to the vehicle over time, and in general, decrease her energy use. The break in the chart was due to the operator needing to take a diesel bus those days for field trips.

**Chart showing kWh per mile in the first weeks of service at EUHSD**

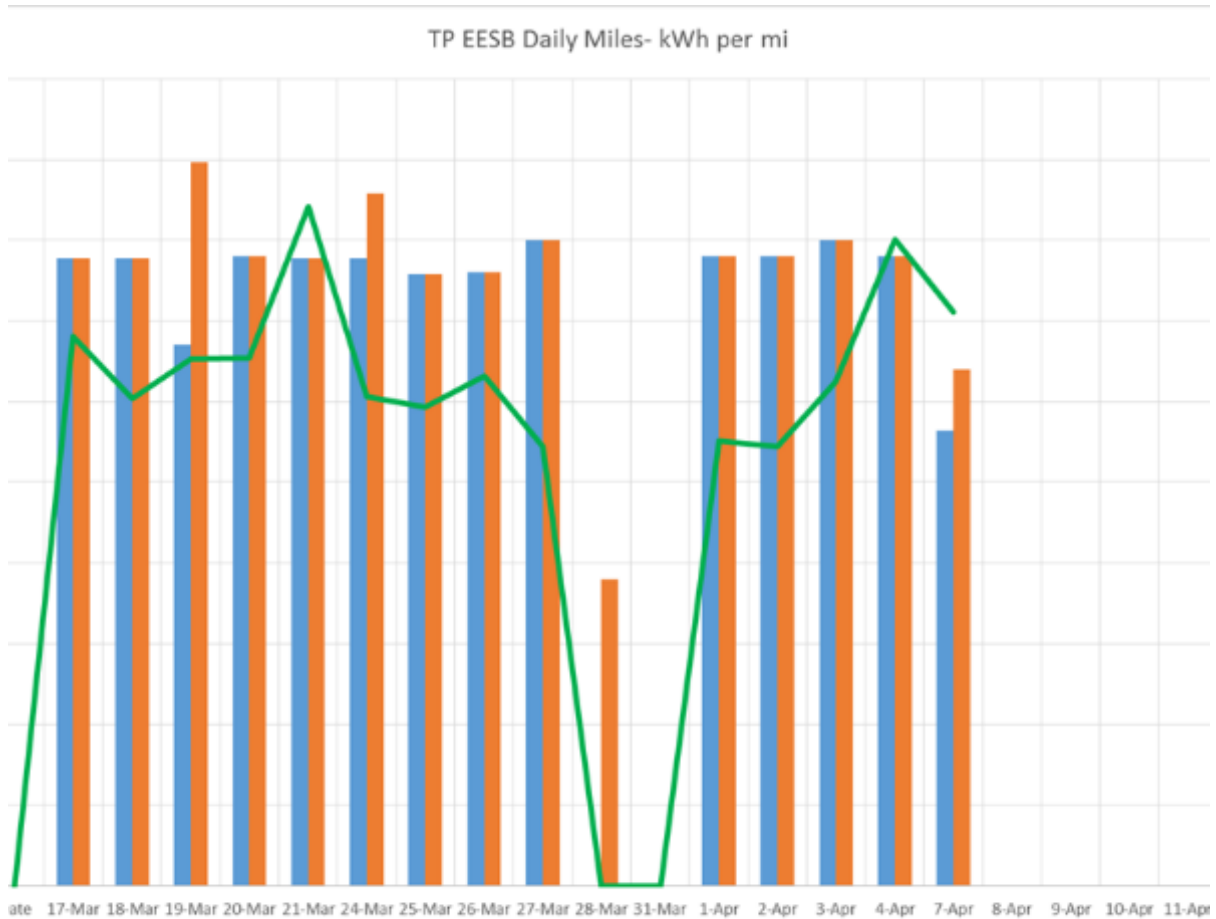

Figure 20. EESB Daily Miles and kWh/mi AC in first weeks at EUHSD

## Economical Electric School Bus EESB Final Report June 2<sup>nd</sup>, 2014

### 5.3 Project Media Coverage

The EESB was highlighted in several local press reports, and industry trade coverage. Media took a great interest in the story of zero emissions school buses, and their opportunity to provide good stewardship of state dollars to help the environment and the community. Below are a handful of links to various articles and videos about the bus and project:

- KPBS: <http://kpbs.us/NLPBp7>
- ABC 10: <http://youtu.be/aWRma6mHtaU>
- UT San Diego:  
<http://sandiegouniontribune.ca.newsmemory.com/publink.php?shareid=48d268da3>
- School Bus Fleet Mag: <http://www.schoolbusfleet.com/Channel/Green-School-Bus/News/2014/03/27/California-district-pilots-electric-drive-system-on-bus.aspx>
- San Diego County News Center: <http://www.countynewscenter.com/video?v=154437>



Figure 21. EESB Featured in San Diego Union Tribune

### 5.4 Project Lessons Learned

One of the primary goals of the EESB Demonstration Project was to provide some lessons learned to the industry in the application of Electric School Buses. The follow list describes the highlighted lessons learned both technically and programmatically.

- An early partnership with the California Highway Patrol related to CHP 292 approval is key.
- Funds must be allocated up front in the project to each school district for infrastructure installation.
- Route selection and operator training are key to reliability and performance.
- Energy Storage System Balance is critical to vehicle range and charge times.
- 45 mile range bus can be used on a number of local routes, but often School Bus Routes and required distances will change day by day, if not hour by hour. Planning of use of a range limited bus and faster charge rates can help alleviate range anxiety.



Figure 22. EESB at EUHSD Bus Yard

## **6.0 Conclusion**

The Efficient Electric School Bus, EESB, as an early prototype demonstration project has been a resounding success. The EESB was a true Public Private Partnership. As such we'd like to thank the California Air Resources Board (CARB), the San Diego County Air Pollution Control Board (APCD), TransPower, California Highway Patrol (CHP), Escondido Union High School District (EUHSD), Cajon Valley Unified School District (CVUSD), and numerous others key to this product success. This project has allowed for direct data collection on the feasibility of the next generation of full-size, high power, lower cost, and extended range school buses to be used throughout the state of California. As a result of this proof of concept project, additional zero emission school bus projects are in works throughout the state, including TransPower's own Vehicle to Grid (V2G) project, destined to operate six converted Type C school buses at Torrance Unified School District, Napa Unified School District, and Kings Canyon Unified School District. The ability to save thousands of dollars a year in operating and maintenance costs, and generate thousands of dollars a year in vehicle to grid revenue, will create cost effective zero emission pupil transportation for generations to come.